

SIGMA Pressure test equipment



We help you perform even better

Features

SIGMA is the new generation of pressure testing helping our customers prepare for IoT and Industry 4.0.

The system consists of modular airless pressure modules designed to fit into an elegant standard cabinet with a compact footprint. The modularity enables easy configuration and extension of existing pressure cabinets, making SIGMA the most future proof and cost efficient solution in the market.

The web based SIGMA software is the latest development in pressure testing. The browser based interface allows for easy and intuitive operation. Quick-to-setup recipes as well as optimized real time monitoring & logging enabling comprehensive analysis option.

Scope

SCITEQ SIGMA pressure solution determines the resistance (both long term and short term) to internal pressure on thermoplastic pipes, fittings and assemblies for conveyance of fluids.

The product design complies with following pipe diameter configurations:

- Up to Ø800 [mm] pipe diameter in long term test, provided the total volume expansion of the test specimen until pressure set point is reached is less than 120dm³ within 1 hour from test startup (max allowed pressuring time is 1 hour according to ISO1167 and max flow rate pr. SUB station is 2l/min)
- Up to Ø315 [mm] pipe diameter in short term test, provided the total volume expanding until fracture (burst) is less than 10.5dm³ within 70 seconds from test startup (max allowed pressuring time is 70s according to ASTM D1599 and max flow rate in a BURST station is 9l/min)

DPCS

SCITEQ's intelligent Dynamic Pressure Control System ensures that test pressures are maintained with unparalleled accuracy no matter what size sample is connected to the system. Static, burst and cyclic testing can all be accommodated.

Flow per station: max. flow 2 l/min (max. flow 9 l/min for burst). For other valve flow and power pack flow configurations, refer to the SCITEQ HCP solutions.

Alarm

The built-in alarm light instantly alerts the operator visually in case of irregularities in the ongoing test.

SIGMA PowerPack module

Pressure source feed to all X-ACT SUB modules. Various models available incl./excl.output for optional BURST modules. With built-in high pressure pump and 10 micron inlet filter.

- ✓ Max. 100 or 160 bar regulated pressure output.
- ✓ Max. 200bar unregulated output (optional)
- ✓ Max. flow: 17 l/min.

SIGMA SUB module

Provides 5 or 10 independently operating pressure stations up to max. 100 or 160 bar. Semi-automatic individual pressure transmitter calibration through integrated main transmitter is optional. Built-in fast reacting valves for precise pressure control.

- ✓ Max. 100 or 160 bar regulated pressure output
- ✓ Max. flow per station: 2 l/min.



SIGMA BURST module

Provides one linear burst pressure station up to max. 200bar within 60-70 seconds. Built-in fast reacting high flow and pressure valves for fast and precise pressure control. Requires PowerPack module with output for BURST module.

- ✓ Max. 200bar regulated pressure output
- ✓ Max. flow: 15l/min.

SIGMA HCP3 module

Provides three independently high volume operating pressure stations up to max. 100bar regulated pressure output. Built-in fast reacting valves for precise pressure control.

- ✓ 3 individual stations
- ✓ Max. 100bar
- ✓ Max. flow: 15 l/min.



About SIGMA modularity

SCITEQ

SIGMA Cyclic module

Provides a cyclic "saw tooth" pressure output between 5 to 10bar or 5 to 30bar. Test frequency up to 1Hz, 60 cycles per minute. Built-in high pressure pump, 10 micron inlet filter and water tank for recirculation of water.

- ✓ Cyclic pressure output between 5 to 10bar or 5 to 30bar
- ✓ Max. flow: 4 l/min.



SIGMAlite

The compact plug and play test unit with five fixed individual pressure stations ideal for smaller layouts. Incl. DPC system and ABX valves ensures consistent and unparalleled pressure accuracy.

This cost effective and reliable solution is easy to setup and operate from any device via the web-based software.

The alarm visually alerts the user, in case of irregularities in the ongoing test.

Dimensions: B490xD620xH600 mm



Energy consumption

SCITEQ's Dynamic Pressure Control System uses only approx. 1/3 of power compared to conventional systems.

SCITEQ is the only supplier of the DPCS system. Other systems on the market use pressure pumps that run constantly via a bypass/circulation valve, hence the power consumption will be equal to the motor size + the power consumption for the control unit. As we supply pressure with the DPCS system to a high pressure reservoir the running time of the pump is reduced by more the 90%, thereby significantly reducing the power consumption.

Our PLC control uses an electronic power transformer to generate 24 volt power to the solenoid. This electronic power transformer regulates the output according to the specific need.

Maintenance & service

The smart design of the SIGMA cabinet offers easy access for servicing and the pressure test can operate during service or maintenance.

The manually operated valve for each SUB module isolates each sub (optionally each block of 5 stations) making it possible to run all other stations while servicing 5 or 10. The valves are NC (normally closed), each station will keep pressure when turned off.

Drainage of pressure equipment for servicing only necessary servicing the A valve and this is very rarely necessary.

Standards

The SIGMA pressure solutions complies with the below standards. Referring national, or sub standards referring to the below and others on request .

Long term test: ISO 1167-1:2006
ASTM D1598-02

Short term test: ASTM D5199-99

Harmonized standards: EN ISO 12100-1

EN ISO 12100-2
EN ISO 13849-1
EN ISO 14121-1
EN ISO60204-1

Normative references: Machinery Directive 2006/42/EC
EMC Directive 2004/108/EEC
Low voltage Directive 2006/95/EEC

SIGMA CAB5

Cabinet for SIGMA modules. Extremely compact design allows for installation of up to 40 pressure stations and a PowerPack within a footprint of 800x800mm. External dimensions: 908x800x1805mm (LxWxH). Included is a central power supply rail for all modules and hidden column for hoses to secure a completely closed design cabinet.

SIGMA CAB6

Cabinet for SIGMA modules. Extremely compact design allows for installation of up to 50 pressure stations and a PowerPack within a footprint of 800x800mm. External dimensions: 908x800x2100mm (LxWxH). Included is a central power supply rail for all modules and hidden column for hoses to secure a completely closed design cabinet.



Advantages

SCITEQ's browser-based software is accessible from any device – any time, anywhere.

- ✓ 4 different user levels
- ✓ Easy recipe set-up
- ✓ Dynamically adjusted real-time finish time
- ✓ Multiple simultaneous users
- ✓ Multiple specimen test per station
- ✓ SQL database compatible with all kind of servers



	SIGMA Cab 5/6	SIGMA PowerPack module	SIGMA Control module	SIGMA SUB 5 modules	SIGMA SUB 10 modules	SIGMA Burst module	SIGMA High Capacity Pressure module (HCP3)
Controller type	SCITEQ-B&R S3100 Controller	SCITEQ-B&R S3100 Controller	SCITEQ-B&R S3100 Controller	SCITEQ-B&R S3100 Controller	SCITEQ-B&R S3100 Controller	SCITEQ-B&R S3100 Controller	SCITEQ-B&R S3100 Controller
User interface*	Chrome, Firefox or Internet Explore browser.	Chrome, Firefox or Internet Explore browser	Chrome, Firefox or Internet Explore browser	Chrome, Firefox or Internet Explore browser	Chrome, Firefox or Internet Explore browser	Chrome, Firefox or Internet Explore browser	Chrome, Firefox or Internet Explore browser
Status indicator light build in cabinet front	√	N/A	N/A	N/A	N/A	N/A	N/A
Remote accessible	√	√	√	√	√	√	√
Max. water flow	N/A	8,5 l/m (17 l/m on request)	N/A	2 l/m pr. station	2 l/m pr. station	8,5 l/m (up to 15 l/m on request)	8,5 l/m (up to 15 l/m on request)
Max. pressure	100/160 bar (200 bar on request)	100/160 bar (200 bar on request)	100/160 bar (200 bar on request)	100/160 bar (200 bar on request)	100/160 bar (200 bar on request)	100/160 bar (200 bar on request)	100/160 bar (200 bar on request)
Control accuracy	N/A	Better than +/- 1 % of set pressure	N/A	Better than +/- 1 % of set pressure	Better than +/- 1 % of set pressure	Better than +/- 1 % of set pressure	Better than +/- 1 % of set pressure
Control resolution	N/A	0,01 bar	N/A	0,01 bar	0,01 bar	0,01 bar	0,01 bar
Testing according to following standards	ISO1167-1:2006 ASTM D1598-02 ASTM D5199-99	N/A	N/A	ISO1167-1:2006 ASTM D1598-02 ASTM D5199-99	ISO1167-1:2006 ASTM D1598-02 ASTM D5199-99	ASTM D1598-02 ASTM D5199-99	ISO1167-1:2006 ASTM D1598-02 ASTM D5199-99

*SCITEQ is recommending the use of IPAD PRO 11", or similar with screen resolution:2388x1668

	SIGMA Cab 5/6	SIGMA PowerPack module	SIGMA Control module	SIGMA SUB 5 modules	SIGMA SUB 10 modules	SIGMA Burst module	SIGMA High Capacity Pressure module (HCP3)
Pressure rise time	N/A	N/A	Adjustable (customized for specific sample expansion)	Adjustable (customized for specific sample expansion)	Adjustable (customized for specific sample expansion)	Adjustable (customized for specific sample expansion)	Adjustable (customized for specific sample expansion)
Transmitter type*	N/A	Trafag NAH8252 (250 bar)	N/A	Trafag NAH8252	Trafag NAH8252	Trafag NAH8252	Trafag NAH8252
Transmitter accuracy**	N/A	0,5 % FS (25 °C ambient)	N/A	0,5 % FS (25 °C ambient)	0,5 % FS (25 °C ambient)	0,5 % FS (25 °C ambient)	0,5 % FS (25 °C ambient)
Transmitter Control rise time	N/A	2 ms/ 10-90% nominal pressure	N/A	2 ms/ 10-90% nominal pressure	2 ms/ 10-90% nominal pressure	2 ms/ 10-90% nominal pressure	2 ms/ 10-90% nominal pressure
External dimensions HxWxD [mm]	CAB 5: 1960 x 800 x 800 CAB 6: 2300x 800 x 780	730 x 637 x 255	730 x 748 x 90	730 x 475 x 309	730 x 475 x 309	730 x 460 x 305	730 x 760 x 305
Shelve capacity in cabinet	CAB 5: PP + 40 Stations CAB 6: PP + 50 stations	N/A	N/A	N/A	N/A	N/A	N/A
Weight [kg]	CAB 5: Approx 120 CAB 6: Approx 135	Approx: 62	Approx: 28 kg	Approx: 38	Approx: 65	Approx: 21	Approx: 29
Color	Ral 7016/30 (Dark grey)	Ral 7016/30 (Dark grey)	Ral 7016/30 (Dark grey)	Ral 7016/30 (Dark grey)	Ral 7016/30 (Dark grey)	Ral 7016/30 (Dark grey)	Ral 7016/30 (Dark grey)
Material: cabinet and shelves	S235JR (Powder coated)	S235JR (Powder coated)	S235JR (Powder coated)	S235JR (Powder coated)	S235JR (Powder coated)	S235JR (Powder coated)	S235JR (Powder coated)

*Transmitters are standard available in following sizes: 4, 6,10,16,25,40,60,100,160,250 and 400 bar. Others sizes might be available on request.

** Long term stability 1 year = +/- 0,1 % FS, NLH (BSL) = +/-0,2 % (25°C).

	SIGMA Cab 5/6	SIGMA PowerPack module	SIGMA Control module	SIGMA SUB 5 modules	SIGMA SUB 10 modules	SIGMA Burst module	SIGMA High Capacity Pressure module (HCP3)
Material: Piping and fittings	N/A	AISI 304 and brass	AISI 304 and brass	AISI 304 and brass	AISI 304 and brass	AISI 304 and brass	AISI 304 and brass
Power supply*	3x 400 V+N, 50/60 HZ	3x 400 V+N, 50/60 HZ	3x 400 V+N, 50/60 HZ	3x 400 V+N, 50/60 HZ	3x 400 V+N, 50/60 HZ	3x 400 V+N, 50/60 HZ	3x 400 V+N, 50/60 HZ
Max. power consumption**	Approx: 3,2 KW, 5,7 A (Total for the whole system)	Approx: 3 KW, 5,3 A	N/A	Approx: 0,1 KW	Approx: 0,2 KW	Approx: 0,1 KW	Approx: 0,1 KW
Recommended Fuse	16 A	16 A	16 A	16 A	16 A	16 A	16 A
Supply water filter	N/A	10 My	N/A	N/A	N/A	N/A	N/A
Water supply	Normal clean tap 2-6 bar Min. flow 10 l/m (13 l/m)	Normal clean tap 2-6 bar Min. flow 10 l/m (17 l/m)	Normal clean tap 2-6 bar Min. flow 10 l/m (13 l/m)	Normal clean tap 2-6 bar Min. flow 10 l/m (13 l/m)	Normal clean tap 2-6 bar Min. flow 10 l/m (13 l/m)	Normal clean tap 2-6 bar Min. flow 10 l/m (13 l/m)	Normal clean tap 2-6 bar Min. flow 10 l/m (13 l/m)
Operating and storage temperature	2-37 °C ambient (30-70% RH)	2-37 °C ambient (30-70% RH)	2-37 °C ambient (30-70% RH)	2-37 °C ambient (30-70% RH)	2-37 °C ambient (30-70% RH)	2-37 °C ambient (30-70% RH)	2-37 °C ambient (30-70% RH)
Calibration certificate incl.	√	√	√	√	√	√	√
Land of origin	Denmark	Denmark	Denmark	Denmark	Denmark	Denmark	Denmark
CE Approval	√	√	√	√	√	√	√

*Power supply can be customized .

**Power consumption is for standard but will variate depending on the required flow and pressure of the PowerPack and frequency of the supply grid (standard is 50 Hz).

Dimensions SIGMA thermo tank

SCITEQ

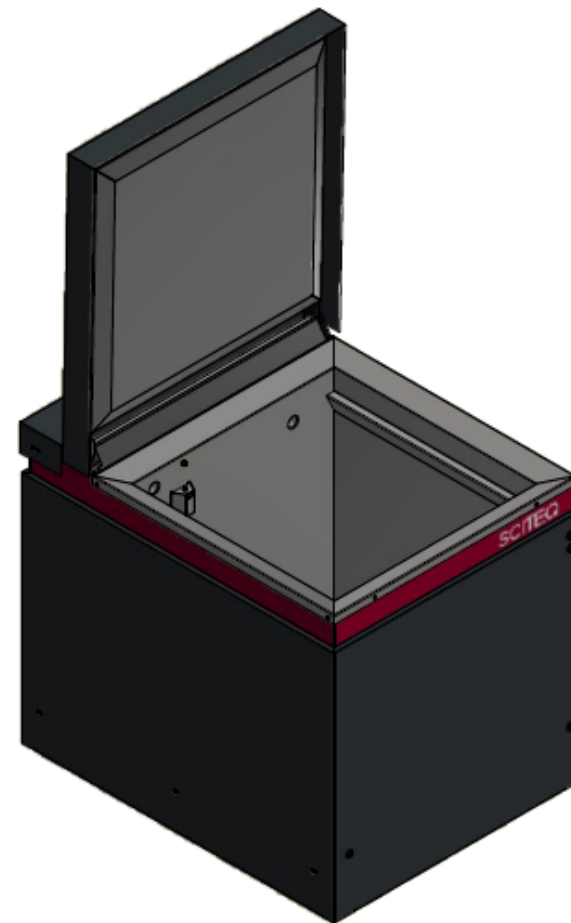
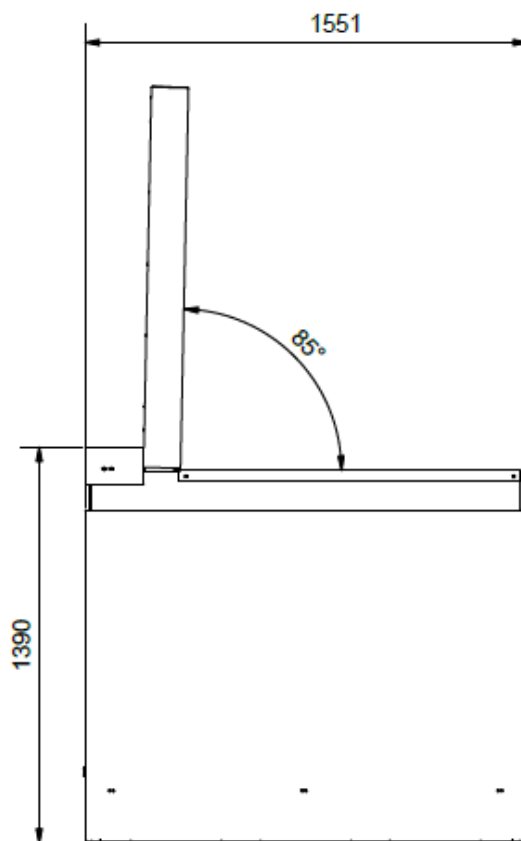
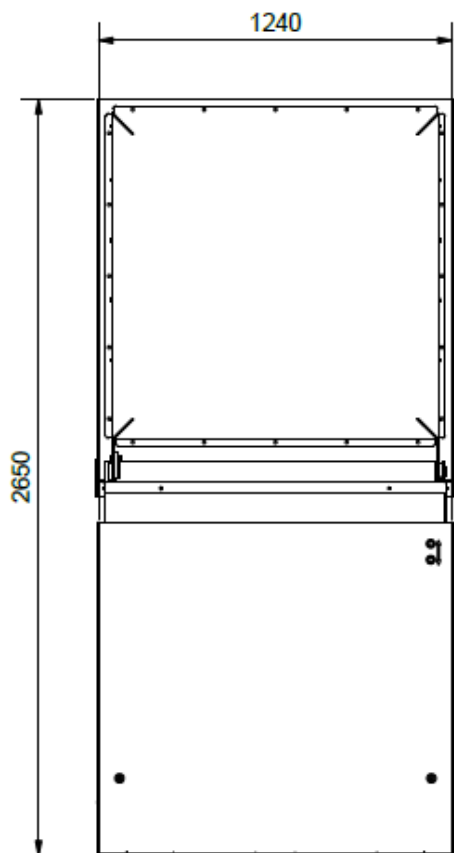

Dimensions SIGMA thermo tank

SCITEQ

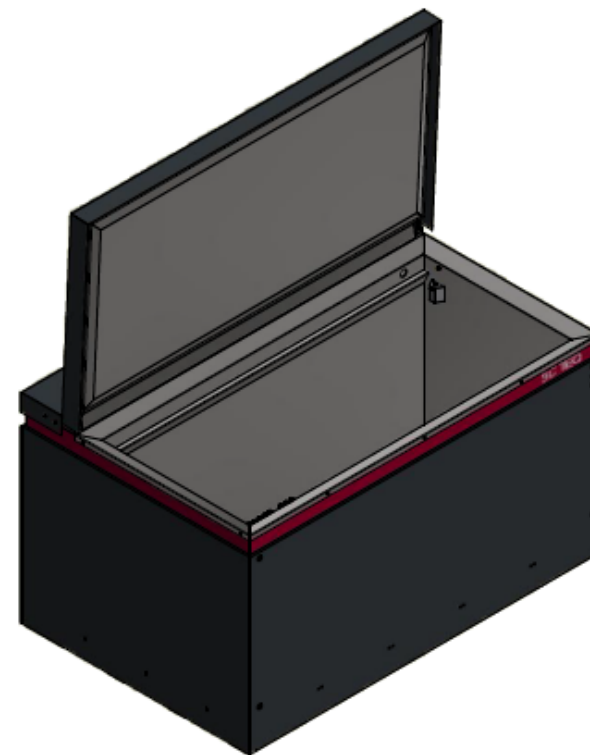
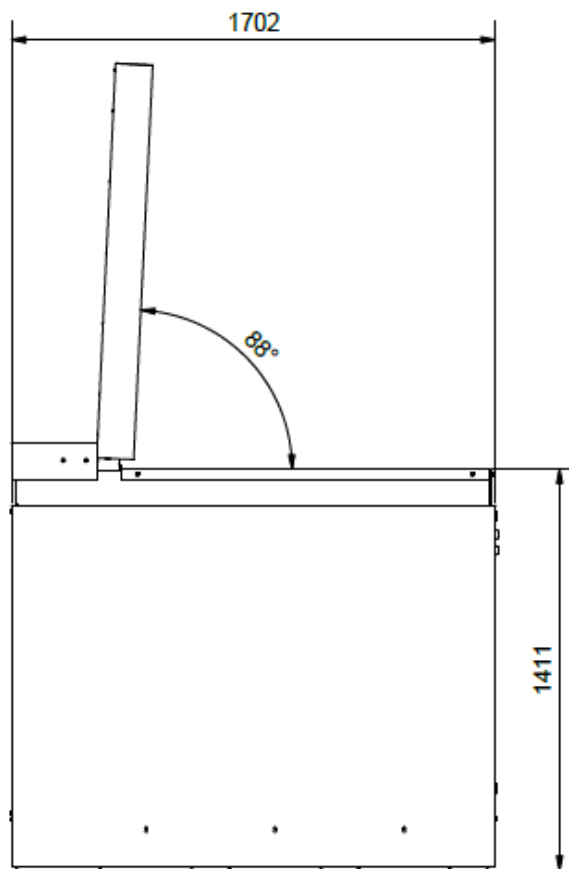
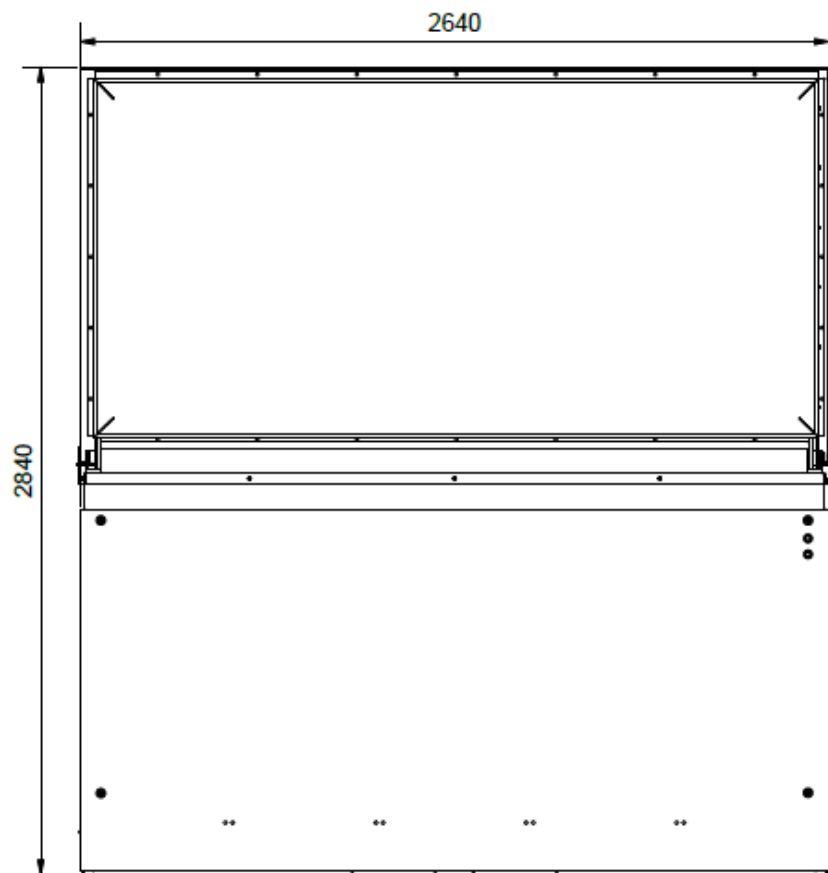

Technical specifications SIGMA Thermo tank



	Standard models	
	1000x1000x1100	2400x1100x1200
Inner tank dimensions [mm]	1000x1000x1100	2400x1100x1200
Water mirror height WH [mm]	Approx: 1000	Approx: 1100
Loading height [mm]	1350	1411
Height with open lid [mm]	2650	2840
Volume [m3]	Approx: 1.1	Approx: 2,9
Weight, empty [kg]	Approx: 500	Approx: 995
Weight with water [kg]	Approx: 1600	Approx: 3895
Material: piping and inner tank and lid*	AISI 304	AISI 304
Material: frame and coverplates	S235JR (Powder coated)	S235JR (Powder coated)
Power supply	3x 400 V, 50/60 HZ	3x 400 V, 50/60 HZ
Power consumption (Heating mode)	Approx: 5 KW, 7,3 A	Approx: 10 KW, 14,4 A
Approx: Heating time (6-95 °C)	12 Hours	26 Hours
SIGMA visual alarm system	√	√

*Other material available on request e.g. AISI 316.

Technical specifications SIGMA Thermo tank



	Standard models	
	1000x1000x1100	2400x1100x1200
Ambient operation temperature	2 – 28 °C	2 – 28 °C
Water temp. range at 22 °C ambient*	22 – 95 °C	22 – 95 °C
Additional Cooling availability (0-20 °C)**	√	√
Power consumption (Cooling mode)	Approx: 7 KW, 10,2 A	Approx: 7 KW, 10,2 A
Water supply	Normal tap 2-6 bar	Normal tap 2-6 bar
Max. recommended no. of inlets	40 pcs	125 pcs
Temperature control accuracy***	±0,5 °C	±0,5 °C
Temp. regulator resolution	0,1 °C	0,1 °C
WEB SCITEQ Software availability	√	√
Calibration certificate	√	√
CE Approval	√	√

*Chiller is required if temperature needed is below ambient.

**Cooling requires additional chiller system, and maybe some changes in automation and piping also.

*** Accuracy is both for Chiller and heating mode.



End closures without tie-bar

available in custom sizes, enabling you to test any pipe diameter. Made in certified stainless steel AISI 304. Also available as acid resistant AISI 316 when needed.



End closures with tie-bar

available in custom sizes, enabling you to test any pipe diameter. Made in certified stainless steel AISI 304. Also available as acid resistant AISI 316 when needed.

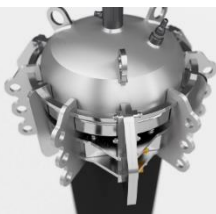

End closures large diameters

Patented design Air frame. For pressure testing of larger pipe diameters from 315 to 1600mm – and larger at request. in certified stainless steel AISI 304.



Hoses

SCITEQ is supplier of hoses to connect pressure stations to thermo tank or to samples. Supplied in different lengths according to need.



Stainless steel hoses

SCITEQ is supplying hoses for use inside the Tank. These are made with inner material suitable for the heat and pressure and protected with stainless outer hose.



Couplings

SIGMA equipment standard couplings are Tema 2510 quick connectors. Other systems can be supplied to fit customer needs.

Essential Equipment



SCITEQ End closures

SCITEQ is supplier of various ranges of end closure suitable for almost any purpose. Within a range of $\varnothing 8$ - $\varnothing 1600$ mm, with or without tie-bars.

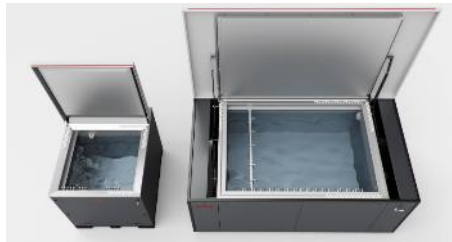

SIGMA thermo tank

The SIGMA thermo tank is the obvious choice to condition test samples. The tank is available in two dimensions suitable for various sample configurations at 0-95° Celsius.

Associated Equipment



SCITEQ Lab saw

For preparing plastic pipe samples by making a parallel cut and chamfering edge. Conveyor with auto feeding. Pipe diam. from $\varnothing 32$ mm to $\varnothing 630$ mm



SCITEQ End closure mounting

& demounting machine. For handling heavy large pipe samples and end closures up to $\varnothing 1600$ mm conveniently and efficiently.



Installation & training

SCITEQ's trained service technicians perform onsite installation of your new SCITEQ equipment as well as onsite or remote training of your operating personnel who will be using the equipment.



Service agreements

With a SCITEQ service agreement you can rest assured your equipment will perform 100% all the time. Specialized service engineers will visit you annually to perform the best service and calibration. You can always liaise with your SCITEQ service technician when in need of advice, looking for new solutions or trying out new equipment.



Support online & on-site

SCITEQ offers online and on-site support on all SCITEQ products, for fast and effective problem solving, training, setup, etc. If you have an unforeseen challenge or you need advise asap, you can contact service@sciteq.com or call us for urgent support.